

**Professional
Products®**

Installation Instructions for Professional Products Throttle Bodies and EGR Plates

Pt. No's. 69200/69203/69500;
69201/69204/69501; 69202/69205/69502
Fits 1986 -'93 Ford Mustang w/5.0L V8 Engine

REMOVAL OF OLD THROTTLE BODY

1. Disconnect the negative (-) battery terminal.
2. The air inlet tube connecting the air cleaner to the throttle body must be removed. Loosen both of the clamps on the air inlet tube and carefully remove it from the vehicle.
3. Disconnect the throttle position sensor and the idle speed control solenoid connectors from the throttle body. Also disconnect the EGR position sensor connector from the EGR valve.
4. Disconnect the EGR vacuum line from the EGR valve. Disconnect the throttle linkage. Loosen the two hose clamps on the throttle body coolant hoses on the EGR spacer. Remove the hoses being aware that some coolant may drain from the hoses.
5. Remove the four nuts that hold the throttle body to the manifold. Slide the stock throttle body and EGR spacer off of the four studs.

INSTALLATION OF NEW THROTTLE BODY

1. For best performance you should use the same size EGR Spacer as Throttle Body. Also, the inlet opening to the manifold should be enlarged to match the diameter of the Throttle Body and EGR Spacer you are using. Note that most 5.0L aftermarket manifolds are sized to match a 70mm throttle body but can be enlarged.
2. Remove the idle speed solenoid and throttle position sensor from the old throttle body and install on the new one. Install the EGR valve on the new EGR plate, using the supplied gasket.
3. Place the EGR spacer gasket over the four studs in the manifold. Slide the EGR spacer into place. Place the throttle body gasket over the four studs. See sketch for correct positioning of gasket. Slide the throttle body over the studs. Re-install the four nuts and torque to 12-18 lb. ft.
4. Connect the throttle position sensor, EGR position sensor and the idle speed control solenoid. Connect the throttle body coolant hoses and tighten clamps. Connect the throttle linkage.
5. Re-install the air inlet tube on the throttle body and air cleaner. Tighten the clamps. Re-install the battery negative terminal.

SETTING ENGINE IDLE SPEED

1. Set the idle speed of the engine as follows:
 - a. Turn the ignition switch to OFF.
 - b. Turn the throttle plate hard stop screw five turns clockwise from the fully closed position.
 - c. Disconnect the idle speed control solenoid connector.
 - d. Start engine and run until it has

reached operating temperature.

e. Turn the throttle plate hard stop screw counter clockwise until the lowest factory idle speed setting (625 rpm) is reached. If the engine has been modified, increased idle speed may be required.

f. Turn the engine off and re-connect the idle speed control connector.

CHECKING T.P. SENSOR VOLTAGE

1. Turn the ignition switch to the ON position but do not start the engine. Using a digital volt/ohmmeter, measure the voltage between the dark green/light green wire and the black wire. Be sure your reading is between 0.8v and 1.0v. Optimum reading is 0.90 to 0.95. This voltage can be adjusted using the special adjustable T.P.Sensor mounting. (See opposite side of this sheet for illustration of adjustable mounting.) Loosen the two socket head cap screws and rotate the T.P. Sensor until the proper reading is achieved. Tighten the screws. Recheck voltage.

Note: Replacement throttle position sensors are available from Professional Products. Order #69209.

EGR Spacer Kit Contents

1 - Polished Aluminum Spacer
1 - 5/16" x 1-1/2 stud
1 - 3/8" x 1-1/2 stud
1 - 5/16" split lock washer
1 - 3/8" split lock washer
1 - 5/16"-24 hex nut
1 - 3/8"-24 hex nut
1 - Gasket: Spacer to Manifold
1 - Gasket: T.B. to EGR Spacer
1 - Gasket: EGR Valve

Throttle Body Kit Contents

1 - Throttle Body Assembly
1 - Gasket: T.B. to EGR Spacer
1 - Gasket: Idle Solenoid to T.B.

Check to make sure
all parts listed are
included in your kit.

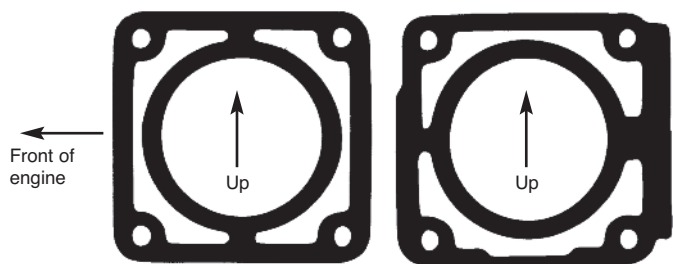

Throttle Body Gasket

Goes between throttle body and EGR spacer.

EGR Spacer Gasket

Goes between EGR spacer and manifold.

Professional Products

12705 S. Van Ness Ave. • Hawthorne, CA 90250
Tech Line - 323-779-2020

Professional Products®

Installation Instructions for Professional Products Throttle Bodies

Pt. No's. 69210, 69211, 69212, 69213, 69214, and 69215

Fits 1994-'95 Ford Mustang w/5.0L V8 Engine

REMOVAL OF OLD THROTTLE BODY

1. Disconnect the negative (-) battery terminal.
2. The air inlet tube connecting the air cleaner to the throttle body must be removed. Loosen both of the clamps on the air inlet tube and carefully remove it from the vehicle.
3. Disconnect the throttle cable. Open the throttle by hand and slip the cable from the groove.
4. Disconnect the throttle position sensor and the idle speed control solenoid connectors from the throttle body.
5. Remove the four nuts that hold the throttle body to the manifold. Slide the stock throttle body off of the four studs.

INSTALLATION OF NEW THROTTLE BODY

1. For best performance, the inlet opening to the manifold should be enlarged to match the diameter of the Throttle Body you are using. Note that most aftermarket 5.0L manifolds are sized to match a 70mm throttle body, but can be opened to accept larger units for higher horsepower engines.
2. Remove the idle speed solenoid and throttle position sensor from the old throttle body and install on the new one. Use the factory screws with the throttle position sensor and idle speed sensor.
3. Place the throttle body gasket over the four studs. Slide the throttle body over the studs. Re-install the four nuts and torque to 12-18 lb. ft.
4. Reconnect the throttle position sensor and the idle speed control solenoid connectors. Re-attach the throttle linkage.
5. Re-install the air inlet tube on the throttle body and air cleaner. Tighten the clamps. Re-install the battery negative terminal.

SETTING ENGINE IDLE SPEED

1. Turn idle speed screw counter-clockwise until the throttle butterfly is fully closed. Then continue to turn idle speed screw counter-clockwise until you can see between the screw and stop (or if using a feeler gauge - .010") then turn clockwise one full turn.
2. Be sure idle valve adjustment screw (slotted head screw inset into side of throttle body, see Figure 1) is turned clockwise until it bottoms in bore. Do not overtighten.
3. Start engine. Allow to idle uninterrupted until at full operating temperature. The computer will make adjustments to find correct idle speed. If vehicle won't idle, turn idle valve adjustment screw counter clockwise in very small incre-

ments, restarting engine after each adjustment until desired idle is achieved.

4. After you have allowed the computer to adjust the idle, if further adjustments are required, a small adjustment can be made to the idle stop screw using a 3mm Allen wrench.

CHECKING T.P. SENSOR VOLTAGE

Turn the ignition switch to the ON position but do not start the engine. Using a digital volt/ohmmeter, measure the voltage between the white wire with a black stripe and the gray wire with a red stripe. Be sure your reading is between 0.8v and 1.0v. Optimum reading is 0.90 to 0.95. This voltage can be adjusted using the special adjustable T.P. Sensor mounting. This unique feature provides you with nearly unlimited easy adjustment of the T.P. Sensor.

Note that with the T.P. Sensor installed on the adjustment plate, one of the attaching screws for the adjustment plate is covered by the T.P. Sensor. Make sure before installing the T.P. Sensor that the screws are only lightly tightened so that it is still possible to rotate the adjustment plate. Install the T.P. Sensor. Using the voltmeter as described above, rotate the adjustment plate until proper reading is achieved. Tighten the one screw that is accessible. Do not overtighten at this point. Remove T.P. Sensor and tighten second screw. Re-install T.P. Sensor. Re-check voltage as it may have changed. There is a minor amount of adjustment in the T.P. Sensor itself due to oversize mounting holes and some clearance where it fits over throttle shaft. You should be able to achieve the correct voltage reading by rotating the T.P. Sensor itself. Tighten T.P. Sensor to adjustment plate. Do not overtighten.

Note: Replacement throttle position sensors are available from Professional Products. Order #69209.

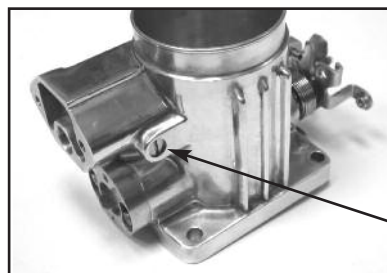

Figure 1

Idle Valve Adjustment Screw

Throttle Body Kit Contents

- 1 - Throttle Body Assembly
- 1 - Gasket: T.B. to EGR Spacer
- 2 - Gasket: Idle Solenoid to T.B.

Check to make sure that all parts are included in kit.

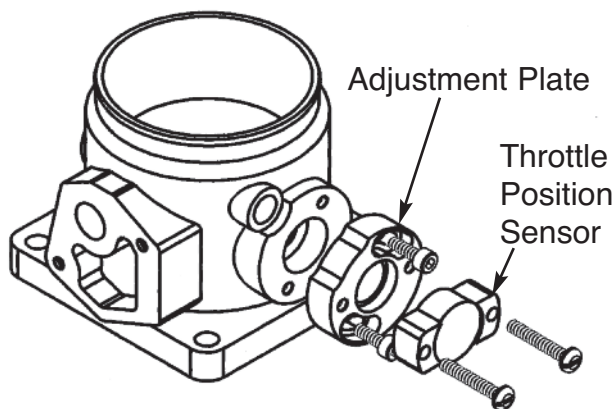

Note: This illustration shows early ('86-'93) style throttle body but Adjustment Plate arrangement is similar for '94-'95 applications.

Professional Products

12705 S. Van Ness Ave. • Hawthorne, CA 90250
Tech Line- 323-779-2020

Revised - 6-3-08